

GLASS D.L.O. FORMULAE:

D.L.O. WIDTH = FRAME WIDTH - 11.750" (X DOORS)
 = (FRAME WIDTH - 22.875")/2 (XX DOORS)
 D.L.O. HEIGHT = FRAME HEIGHT - 16.563"

THESE DOORS ARE NOT RATED FOR IMPACT.
 INSTALLATION OF THIS PRODUCT IN THE HVHZ AREA REQUIRES THE USE OF APPROVED SHUTTERS OR EXTERNAL PROTECTION DEVICES COMPLYING WITH HVHZ REQUIREMENTS.
 INSTALLATION OF THIS SYSTEM OUTSIDE THE HVHZ AREA MUST MEET THE APPLICABLE REQUIREMENTS FOR WIND BORNE DEBRIS PROTECTION.

INSWING WOOD ENTRANCE DOOR

DOORS APPROVED FOR INSTALLATION WHERE WATER INFILTRATION RESISTANCE IS REQUIRED.

THIS PRODUCT HAS BEEN DESIGNED AND TESTED TO COMPLY WITH THE REQUIREMENTS OF THE 2017 (6TH EDITION) FLORIDA BUILDING CODE INCLUDING HIGH VELOCITY HURRICANE ZONE (HVHZ).

1BY OR 2BY WOOD BUCKS & BUCK FASTENERS BY OTHERS, MUST BE DESIGNED AND INSTALLED ADEQUATELY TO TRANSFER APPLIED PRODUCT LOADS TO THE BUILDING STRUCTURE.

ANCHORS SHALL BE CORROSION RESISTANT, SPACED AS SHOWN ON DETAILS AND INSTALLED PER MANUF'S INSTRUCTIONS. SPECIFIED EMBEDMENT TO BASE MATERIAL SHALL BE BEYOND WALL DRESSING OR STUCCO.

A LOAD DURATION INCREASE IS USED IN DESIGN OF ANCHORS INTO WOOD ONLY.

ALL SHIMS TO BE HIGH IMPACT, NON-METALLIC AND NON-COMPRESSIBLE.

MATERIALS INCLUDING BUT NOT LIMITED TO STEEL/METAL SCREWS, THAT COME INTO CONTACT WITH OTHER DISSIMILAR MATERIALS SHALL MEET THE REQUIREMENTS OF THE 2017 FLORIDA BLDG. CODE & ADOPTED STANDARDS.

THIS PRODUCT APPROVAL IS GENERIC AND DOES NOT PROVIDE INFORMATION FOR A SITE SPECIFIC PROJECT, i.e. LIFE SAFETY OF THIS PRODUCT, ADEQUACY OF STRUCTURE RECEIVING THIS PRODUCT AND SEALING AROUND OPENING FOR WATER INFILTRATION RESISTANCE ETC.
 CONDITIONS NOT SHOWN IN THIS DRAWING ARE TO BE ANALYZED SEPARATELY, AND TO BE REVIEWED BY BUILDING OFFICIAL.

MANUFACTURER'S LABEL SHALL BE LOCATED ON A READILY VISIBLE LOCATION IN ACCORDANCE WITH SECTION 1709.9.3 OF FLORIDA BUILDING CODE. LABELING TO COMPLY WITH SECTION 1709.9.2.

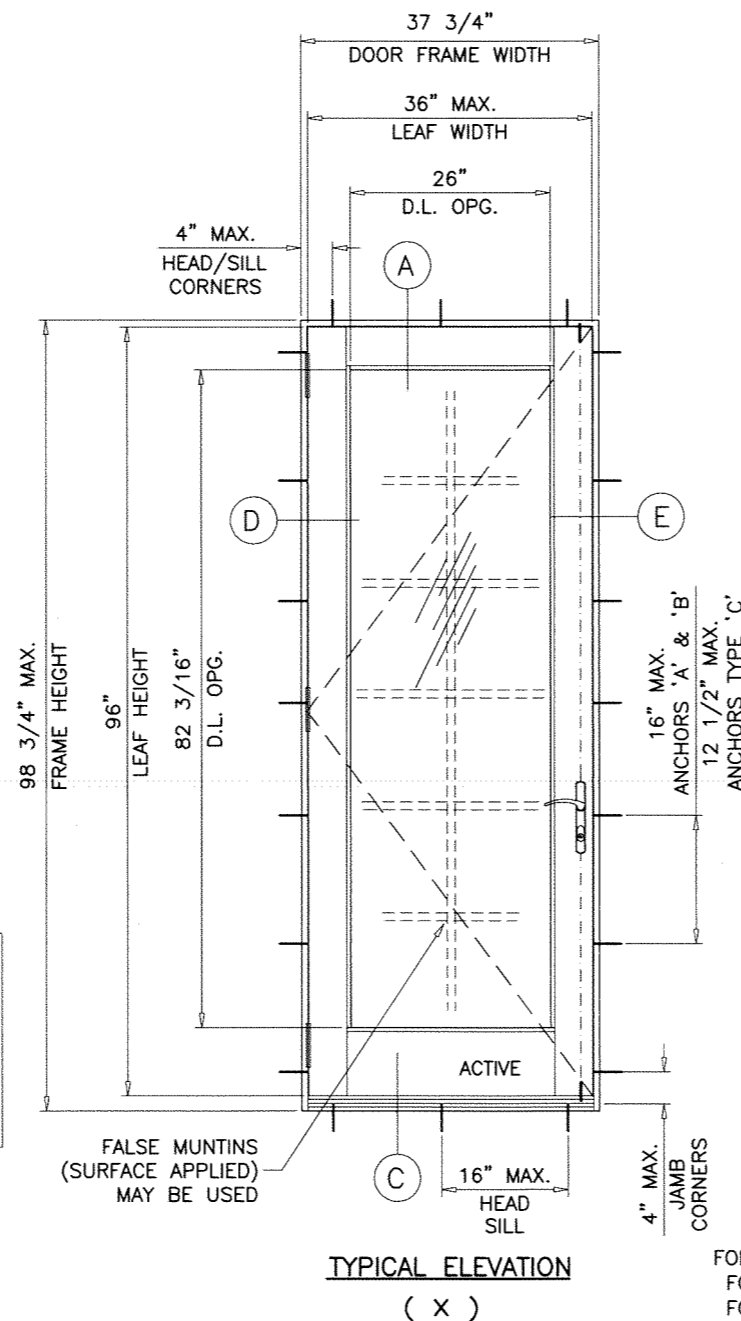

TYPICAL ELEVATION (X)

SINGLE DOOR (X) LOAD CAPACITY - PSF			
DOOR DIMS.		GLASS 'A', 'A1', 'A2' & SHAKER/RAISED PANEL	
FRAME WIDTH	FRAME HEIGHT	EXT.(+)	INT.(-)
37-3/4"	82"	60.0	72.3
37-3/4"	84"	60.0	70.5
37-3/4"	90"	60.0	65.8
37-3/4"	96"	60.0	61.7
37-3/4"	98-3/4"	60.0	60.0

NOTE:
 EGRESS REQUIREMENTS TO BE REVIEWED BY BUILDING OFFICIAL.

NOTE:
 GLASS CAPACITIES ON THIS SHEET ARE BASED ON ASTM E1300-09 (3 SEC. GUSTS) AND FLORIDA BUILDING COMMISSION DECLARATORY STATEMENT DCA05-DEC-219

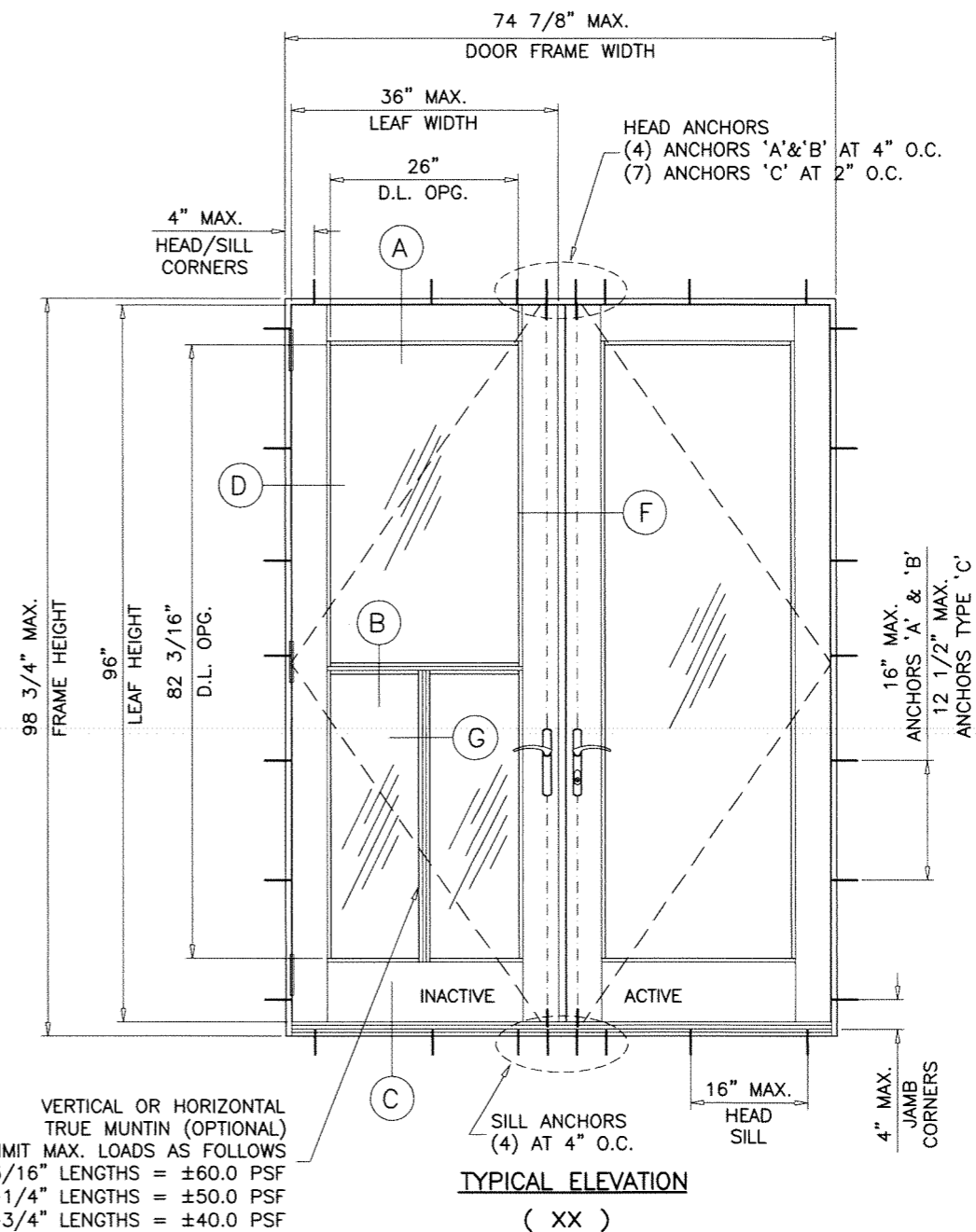

TYPICAL ELEVATION (XX)

DOUBLE DOOR (XX) LOAD CAPACITY - PSF			
DOOR DIMS.		GLASS 'A', 'A1', 'A2' & SHAKER/RAISED PANEL	
FRAME WIDTH	FRAME HEIGHT	EXT.(+)	INT.(-)
74-7/8"	82"	60.0	72.3
74-7/8"	84"	60.0	70.5
74-7/8"	90"	60.0	65.8
74-7/8"	96"	60.0	61.7
74-7/8"	98-3/4"	60.0	60.0

A- CONTRACTOR TO BE RESPONSIBLE FOR THE SELECTION, PURCHASE AND INSTALLATION OF THIS PRODUCT BASED ON THIS PRODUCT EVALUATION PROVIDED HE/SHE DOES NOT DEVIATE FROM THE CONDITIONS DETAILED ON THIS DOCUMENT.
 B- THIS PRODUCT EVALUATION DOCUMENT WILL BE CONSIDERED INVALID IF ALTERED BY ANY MEANS.
 C- SITE SPECIFIC PROJECTS SHALL BE PREPARED BY A FLORIDA REGISTERED ENGINEER OR ARCHITECT WHICH WILL BECOME THE ENGINEER OF RECORD (E.O.R.) FOR THE PROJECT AND WHO WILL BE RESPONSIBLE FOR THE PROPER USE OF THE P.E.D. ENGINEER OF RECORD, ACTING AS A DELEGATED ENGINEER TO THE P.E.D. ENGINEER SHALL SUBMIT TO THIS LATTER THE SITE SPECIFIC DRAWINGS FOR REVIEW.
 D- THIS P.E.D. SHALL BEAR THE DATE AND ORIGINAL SEAL AND SIGNATURE OF THE PROFESSIONAL ENGINEER OF RECORD THAT PREPARED IT.

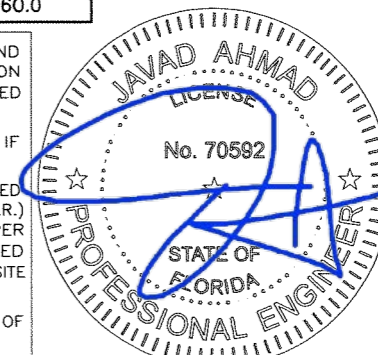

FL #27973

Sealed 8/24/2018

af c
AL-FAROOQ CORPORATION
 ENGINEERS & PRODUCT DEVELOPMENT
 9360 SUNSET DRIVE, SUITE 220 (C.A.N. 3538)
 MIAMI, FLORIDA 33173 FAX (305) 262-6978
 TEL (305) 264-8100

INSWING WOOD ENTRANCE DOOR (N.I.)
Exclusive Wood Doors, Inc.
 2000 N.W. 95th Ave.
 Doral, FL. 33172
 Tel. (305) 477-2278 Fax. (305) 477-7140

revisions:
 no. date by description
 date: 08-13-18
 scale: 1/2" = 1'-0"
 dr. by: TARIQ
 chk. by:
 drawing no.
18-79F
 sheet 1 of 10

COMP-ANL\18-79F-EWD

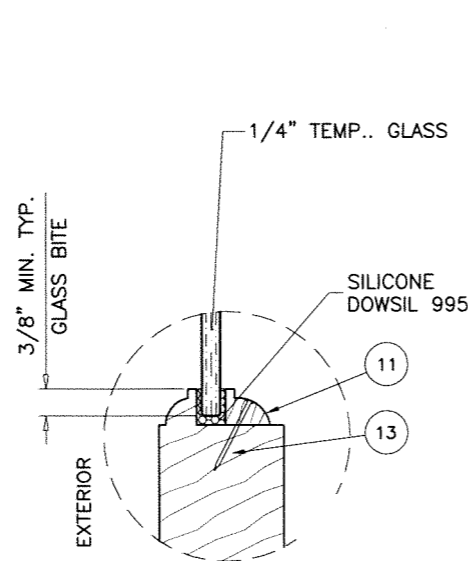
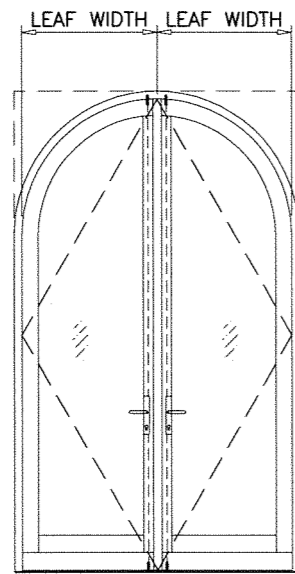
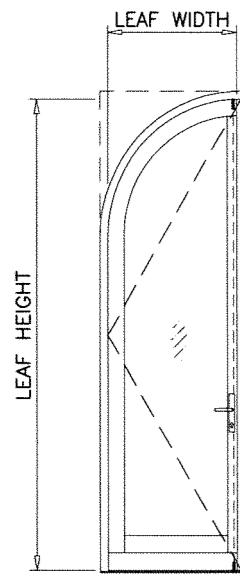

GLASS TYPE 'A'

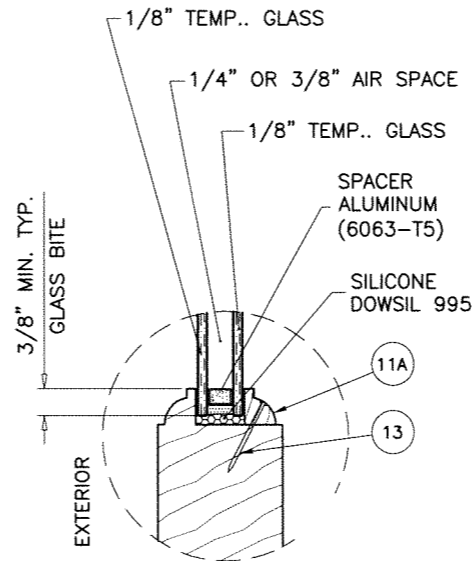

GLASS TYPE 'A1'

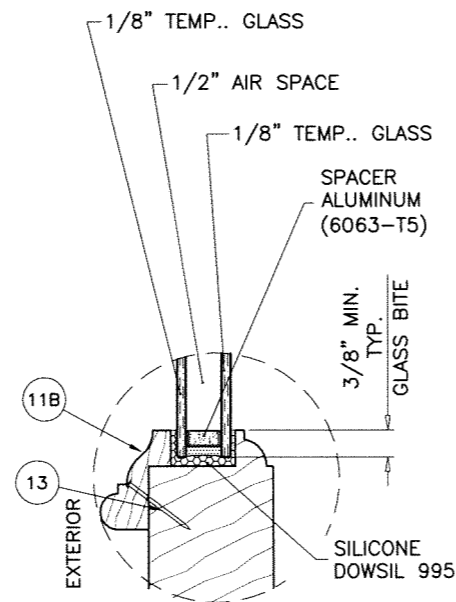
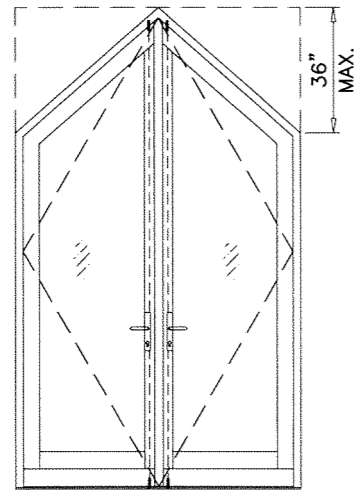
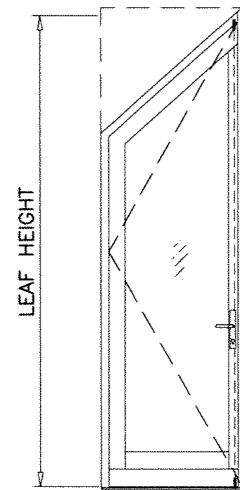

GLASS TYPE 'A1'

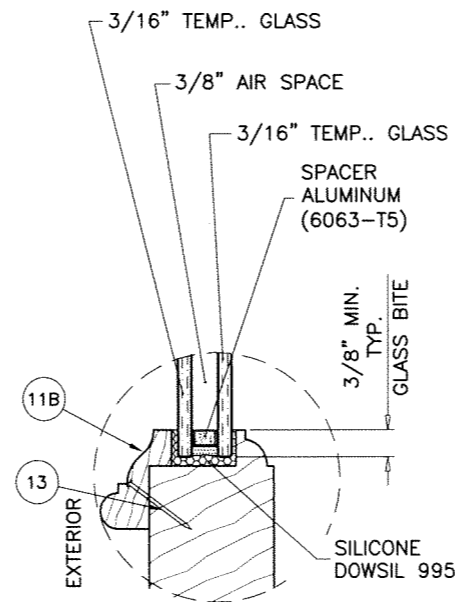

GLASS TYPE 'A2'

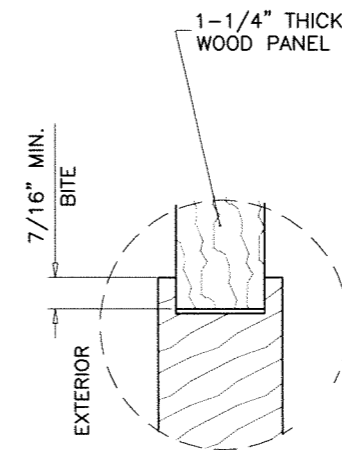

SHAKER PANEL

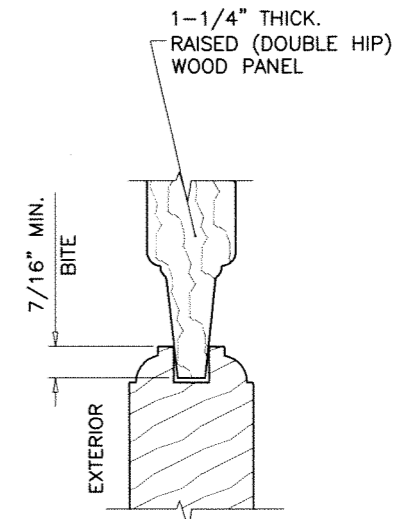

RAISED PANEL

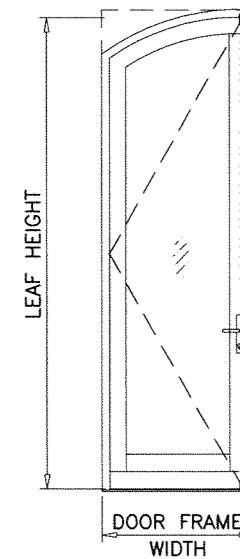

(X)

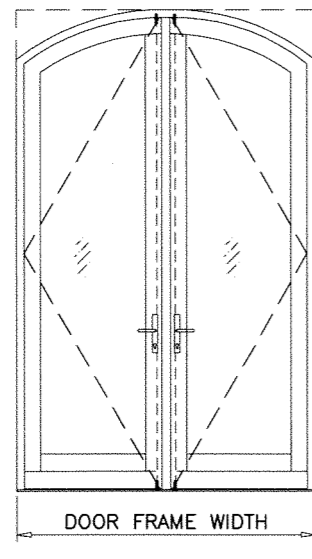

(XX)

ALLOWABLE LOADS FOR ALTERNATE SHAPES AS SHOWN ABOVE OR SIMILAR CAN BE VERIFIED BY INSCRIBING DOOR SHAPE WITHIN RECTANGLE AS SHOWN IN DOTTED LINES AND OBTAINING ALLOWABLE LOADS FROM THOSE SHAPES.

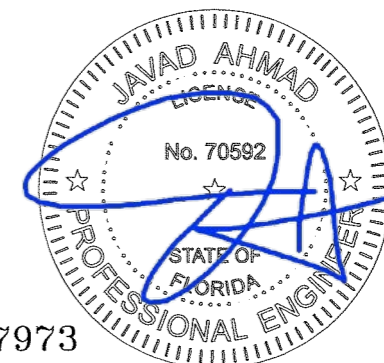

FL #27973

Sealed 8/24/2018

afc
AL-FAROOQ CORPORATION
 ENGINEERS & PRODUCT DEVELOPMENT
 9360 SUNSET DRIVE, SUITE 220
 MIAMI, FLORIDA 33173 (C.A.N. 3538)
 TEL. (305) 264-8100 FAX. (305) 262-6978
 COMP-ANL 18-79F-EWD

INSWING WOOD ENTRANCE DOOR (N.I.)
 Exclusive Wood Doors, Inc.
 2000 N.W. 95Th Ave.
 Doral, FL. 33172
 Tel. (305) 477-2278 Fax. (305) 477-7140

revisions:	no	date	description

date:	08-13-18
scale:	1/2"=1'-0"
dr. by:	TARIQ
chk. by:	
drawing no.	18-79F
sheet	2 of 10

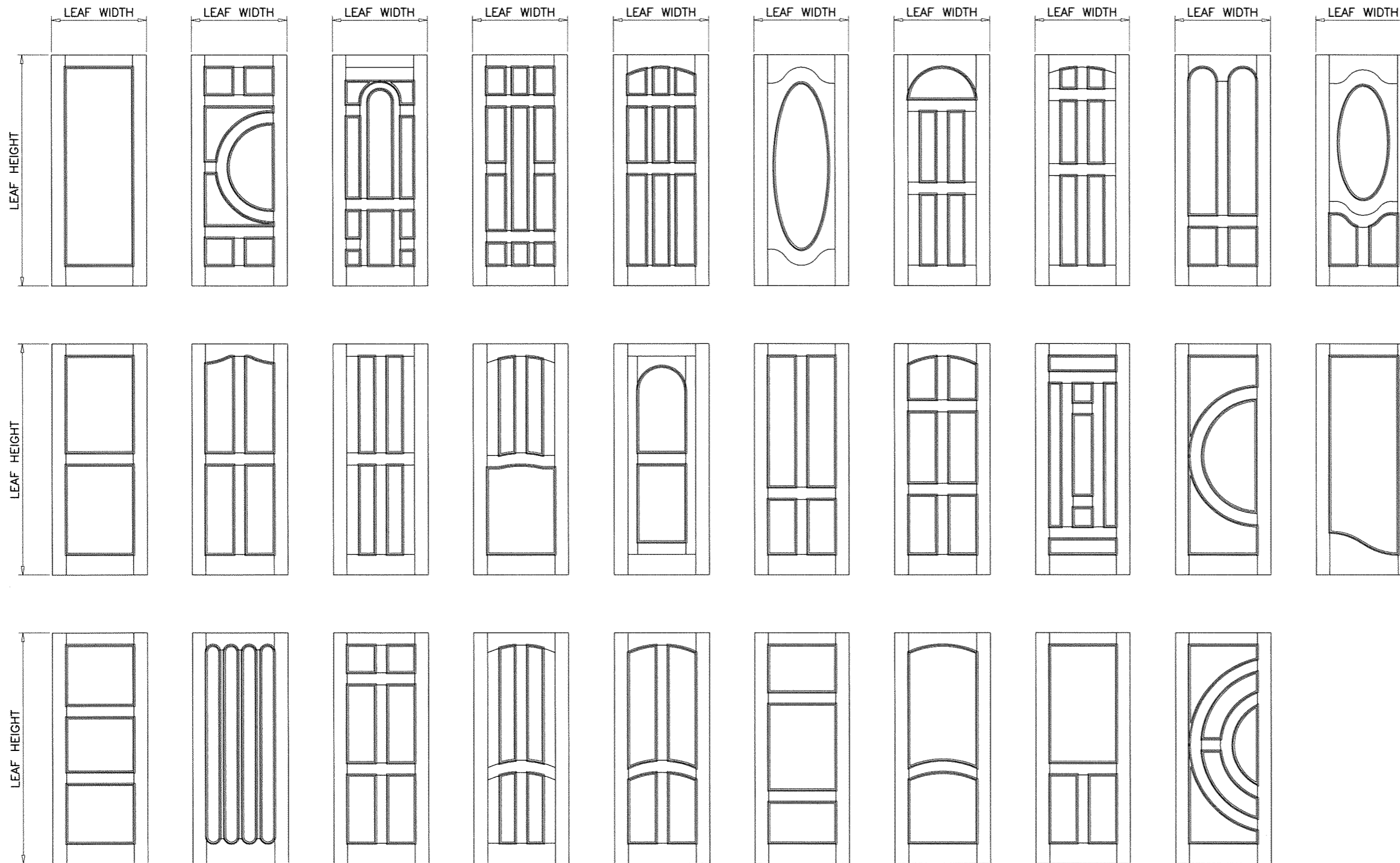

LEAF PATTERNS AS SHOWN ABOVE OR SIMILAR WITH VARIOUS FINISHES AND DECORATIVE MOULDINGS GLAZED WITH SOLID WOOD INSERTS ARE ALSO ALLOWED.

MINIMUM DIMENSIONS:
 TOP RAILS.....5.313"
 BOTTOM RAILS.....8.50"
 LOCK AND HINGE STILES.....5.0"
 TRUE MUNTINS.....1-1/2"

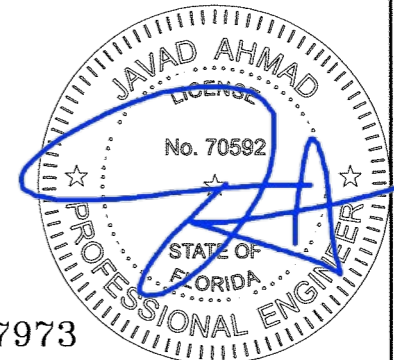

FL #27973

Sealed 8/24/2018

afc
AL-FAROOQ CORPORATION
 ENGINEERS & PRODUCT DEVELOPMENT
 9360 SUNSET DRIVE, SUITE 220 (C.A.N. 3538)
 MIAMI, FLORIDA 33173 FAX. (305) 262-6978
 TEL. (305) 264-8100 COMP-ANL\18-79F-EWD

INSWING WOOD ENTRANCE DOOR (N.I.)
Exclusive Wood Doors, Inc.
 2000 N.W. 95Th Ave.
 Doral, FL. 33172
 Tel. (305) 477-2278 Fax. (305) 477-7140

revisions:	no	date	by	description

date	08-13-18
scale:	-
dr. by:	TARIQ
chk. by:	
drawing no.	18-79F
sheet	3 of 10

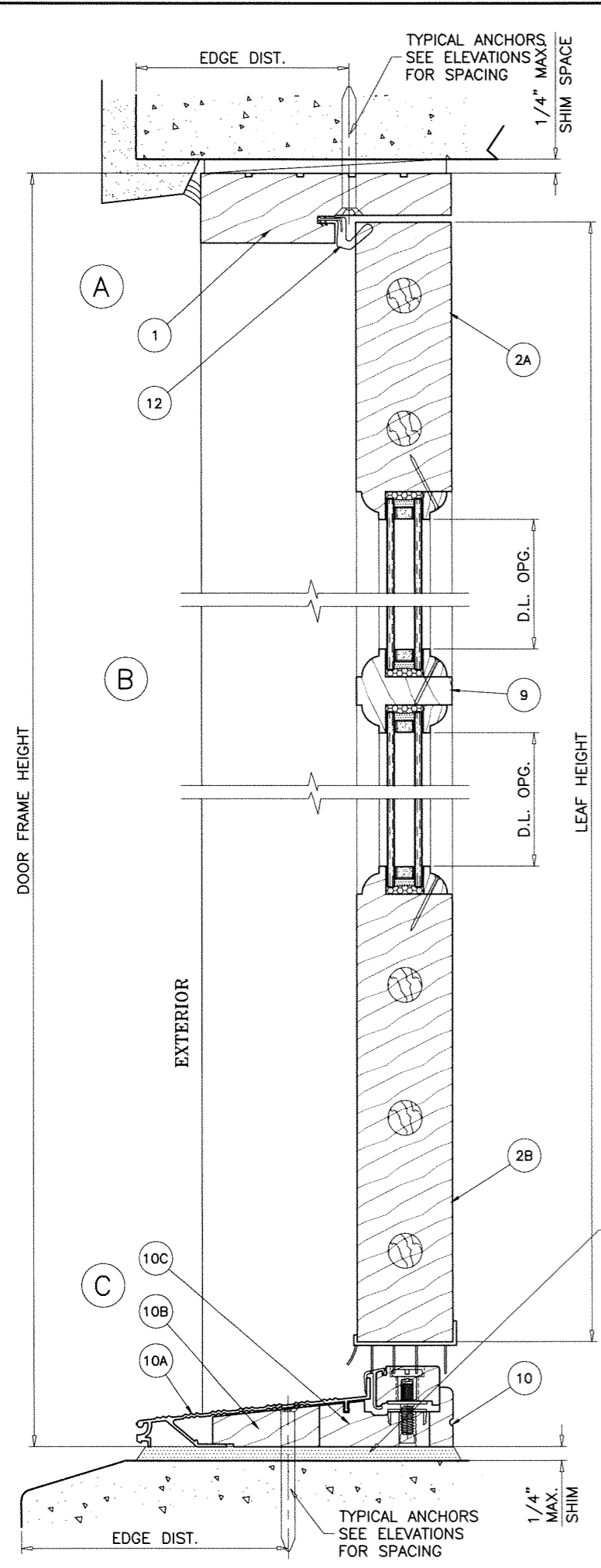

POURED & HARDENED
HIGH STRENGTH GROUT
f'c = 5000 PSI MIN.
NOT BY EXCLUSIVE WOOD DOORS
MUST TRANSFER SHEAR
LOADS TO STRUCTURE
LOAD BEARING
(SOLID SHIMS
OPTIONAL TO GROUT)

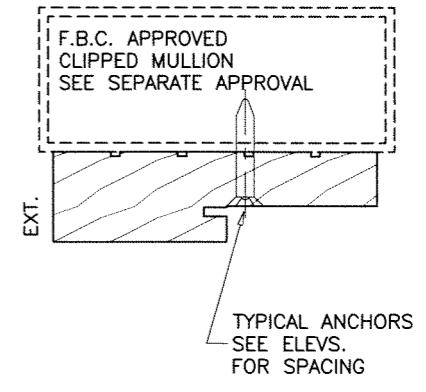
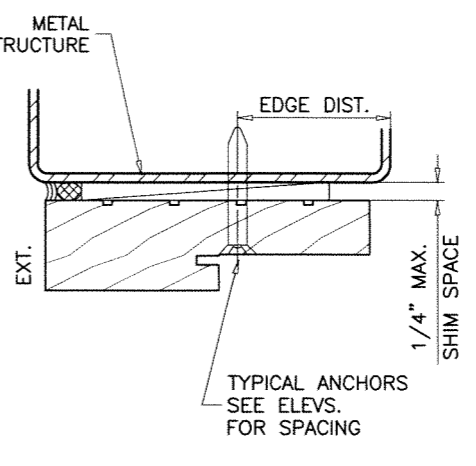
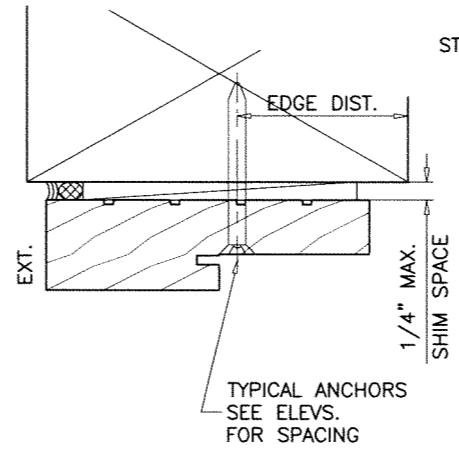
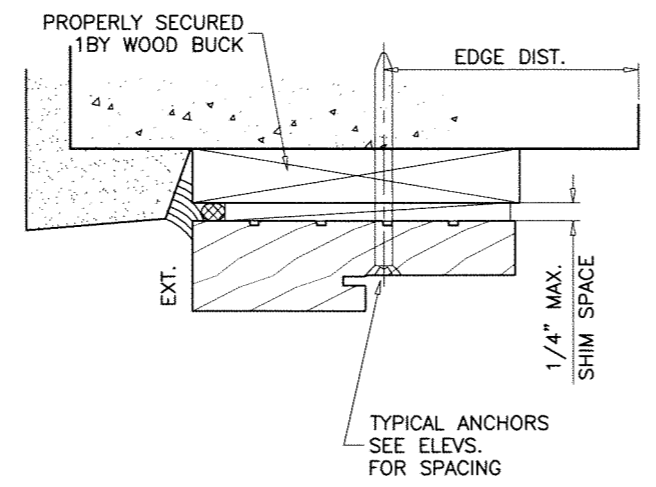

1BY OR 2BY WOOD BUCKS AND METAL STRUCTURE NOT BY EXCLUSIVE WOOD DOORS MUST SUSTAIN LOADS IMPOSED BY GLAZING SYSTEM AND TRANSFER THEM TO THE BUILDING STRUCTURE.

TYPICAL ANCHORS: SEE ELEV. FOR SPACING

- TYPE 'A' - #14 WOOD SCREWS (GRADE 2 CRS)
INTO 2BY WOOD BUCKS OR WOOD STRUCTURES
1-1/2" MIN. PENETRATION INTO WOOD (HEAD/JAMBS)
- TYPE 'B' - 1/4" DIA. TAPCON BY 'ITW' (Fu=125 KSI, Fy=100 KSI)
THRU 1BY BUCKS INTO CONC. OR BLOCKS
1-1/2" MIN. EMBED INTO CONCRETE (HEAD/JAMBS)
1-1/4" MIN. EMBED INTO BLOCKS (JAMBS)
DIRECTLY INTO CONCRETE OR BLOCKS
1-1/2" MIN. EMBED INTO CONCRETE (HEAD/SILL/JAMBS)
1-1/4" MIN. EMBED INTO BLOCKS (JAMBS)
- TYPE 'C' - 1/4"-20 TEKS OR SELF-DRILLING SCREWS (GRADE 5 CRS)
INTO F.B.C. APPROVED MULLIONS
OR
INTO METAL STRUCTURES (HEAD/JAMBS)
(3) THREADS MIN. TO EXTEND BEYOND METAL THICKNESS
ALUMINUM: 1/8" THK. MIN. (6063-T5 MIN.)
STEEL: 1/8" THK. MIN. (Fy = 36 KSI MIN.)
(STEEL IN CONTACT WITH ALUMINUM TO BE PLATED OR PAINTED)

CRITICAL EDGE DISTANCE

- INTO CONCRETE AND BLOCKS = 2-1/2" MIN.
- INTO WOOD STRUCTURE = 1" MIN.
- INTO METAL STRUCTURE = 3/4" MIN.

WOOD AT HEAD OR JAMBS SG = 0.55 MIN.
CONCRETE AT HEAD, SILL OR JAMBS f'c = 3000 PSI MIN.
C-90 HOLLOW/FILLED BLOCK AT JAMBS f'm = 2000 PSI MIN.

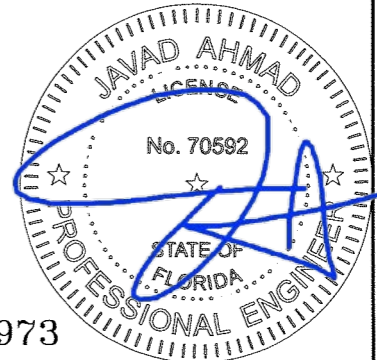

FL #27973

af c
AL-FAROOQ CORPORATION
ENGINEERS & PRODUCT DEVELOPMENT
9360 SUNSET DRIVE, SUITE 220 (C.A.N. 3538)
MIAMI, FLORIDA 33173 FAX (305) 262-6978
TEL (305) 264-8100 COMP-ANL 18-79F-EWD

INSWING WOOD ENTRANCE DOOR (N.I.)
Exclusive Wood Doors, Inc.
2000 N.W. 95Th Ave.
Doral, FL. 33172
Tel. (305) 477-2278 Fax. (305) 477-7140

revisions:	no	date	by	description

date: 08-13-18
scale: 3/8" = 1"
dr. by: TARIQ
chk. by:
drawing no.
18-79F
sheet 4 of 10

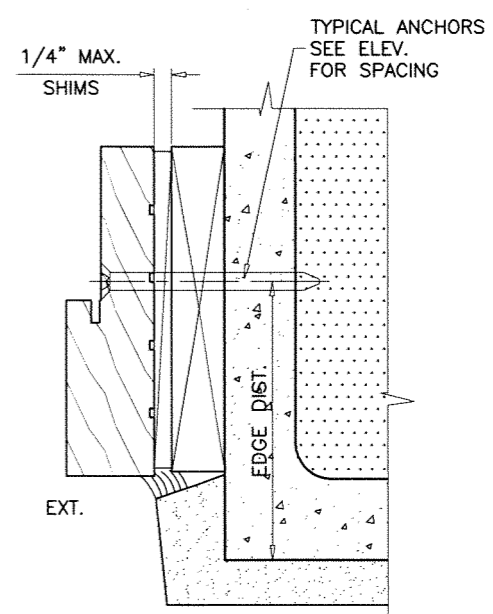
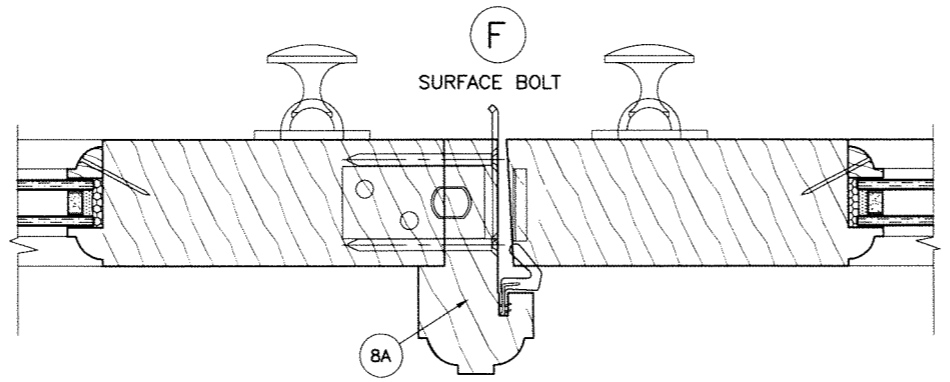
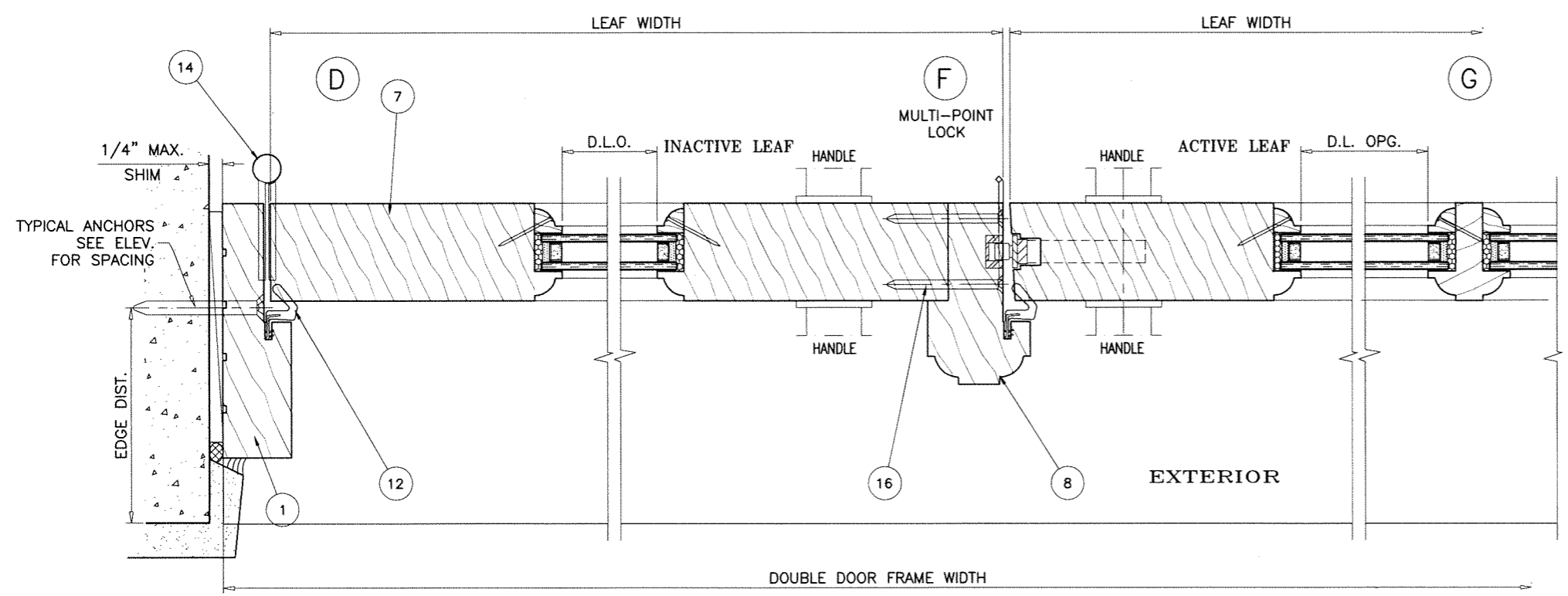
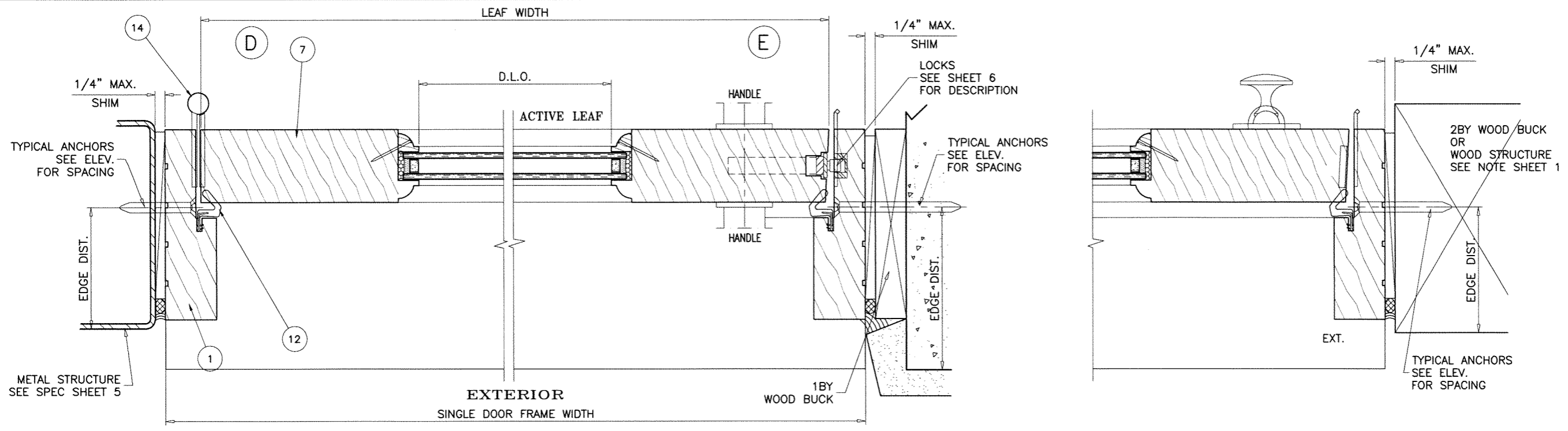

af c
AL-FAROOQ CORPORATION
 ENGINEERS & PRODUCT DEVELOPMENT
 9360 SUNSET DRIVE, SUITE 220 (C.A.N. 3538)
 MIAMI, FLORIDA 33173 FAX. (305) 262-6978
 TEL. (305) 264-8100 COMP-ANL\18-79F-EWD

INSWING WOOD ENTRANCE DOOR (N.I.)
Exclusive Wood Doors, Inc.
 2000 N.W. 95TH Ave.
 Doral, FL 33172
 Tel. (305) 477-2278 Fax. (305) 477-7140

revisions:	no	date	description

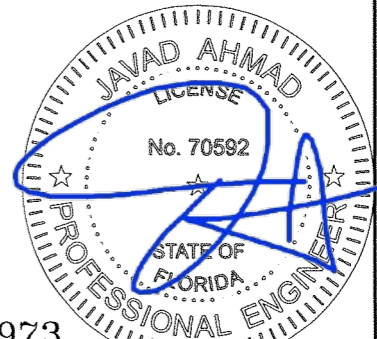

FL #27973

date: 08-13-18
 scale: 3/8" = 1"
 dr. by: TARIQ
 chk. by:
 drawing no.
18-79F
 sheet 5 of 10

Sealed 8/24/2018

ITEM #	PART #	REQD.	DESCRIPTION	MATERIAL	MANF./SUPPLIER/REMARKS
1	-	3	FRAME HEAD/ JAMB	WOOD	MAHOGANY
2A	-	1/ LEAF	TOP RAILS	WOOD	MAHOGANY
2B	-	1/ LEAF	BOTTOM RAILS	WOOD	MAHOGANY
4	-	AS REQD.	RAIL EXTENSIONS	WOOD	MAHOGANY
5	-	1/ LEAF	TOP RAIL SHAKER PANEL	WOOD	MAHOGANY
6	-	1/ LEAF	BOTTOM RAIL SHAKER PANEL	WOOD	MAHOGANY
7	-	AS REQD.	HINGE/LOCK STILES	WOOD	MAHOGANY
8	-	AS REQD.	ASTRAGAL STILE (MULTI-POINT LOCK)	WOOD	MAHOGANY
8A	-	AS REQD.	ASTRAGAL STILE (SURFACE BOLTS)	WOOD	MAHOGANY
9	-	AS REQD.	TRUE MUNTIN	WOOD	MAHOGANY
10	-	1	THRESHOLD COVER	WOOD	MAHOGANY
10A	-	1	THRESHOLD	6063-T6	MAHOGANY
10B	-	1	EXTERIOR SILL FRAME	WOOD	MAHOGANY
10C	-	1	INTERIOR SILL FRAME	WOOD	MAHOGANY
10D	-	1	INTERIOR COVER	WOOD	MAHOGANY
11	-	4/ LEAF	GLASS STOP	WOOD	MAHOGANY
11A	-	4/ LEAF	GLASS STOP	WOOD	MAHOGANY
11B	-	4/ LEAF	GLASS STOP	WOOD	MAHOGANY
12	-	AS REQD.	Q-LON WEATHERSEAL	-	-
13	-	-	18 GA. X 1-1/4" BRAD NAILS	-	2" FROM ENDS & 12" O.C.
14	-	4/ LEAF	BUTT HINGES	-	-
15	#10 X 2-1/2"	AS REQD.	FRAME ASSEMBLY FASTENERS	ST. STEEL	FH SCREWS
16	#7 X 2-1/4"	AS REQD.	ASTRAGAL FASTENERS	ST. STEEL	FH SCREWS, AT 1" FROM ENDS & 18" O.C.

TYPICAL WOOD MAHOGANY LUMBER
 SPECIFIC GRAVITY = 0.44 MIN.
 GRADE = 2 MIN.
 MOISTURE CONTENT = 19% MAX.

LOCKS:

OPTION #1:

ACTIVE LEAF:

MULTI-POINT LOCK ASSEMBLY BY 'GU'
 (3) LOCKING POINTS ENGAGING TO INACTIVE LEAF
 3/8" DIA. BOLTS WITH 3/4" THROW (1) AT TOP ENGAGING FRAME
 HEAD AND (1) AT BOTTOM ENGAGING FRAME SILL
 LOCK HANDLE LOCATED AT 35" FROM BOTTOM

INACTIVE LEAF:

2 POINT LOCK ASSEMBLY BY 'GU'
 3/8" DIA. BOLTS WITH 3/4" THROW AT TOP AND BOTTOM ENGAGING
 FRAME HEAD AND FRAME SILL
 LOCK LOCATED AT 35" FROM BOTTOM

OPTION #2:

ACTIVE LEAF:

SURFACE BOLTS BY 'DELTANA' (8" MIN.)
 SURFACE MOUNTED AT TOP AND BOTTOM
 OF LOCK STILE WITH
 (4) #8 X 1-1/4" SCREWS

INACTIVE LEAF

SURFACE BOLTS BY 'DELTANA' (8" MIN.)
 SURFACE MOUNTED AT TOP AND BOTTOM
 OF LOCK STILE WITH
 (4) #8 X 1-1/4" SCREWS
 CONCEALED FLUSH BOLTS BY 'DELTANA'
 LOCATED AT 18" FROM TOP AND 12"
 FROM BOTTOM ON THE ASTRAGAL
 FASTENED WITH
 (2) #8 X 1" SCREWS

STEEL HINGES:

BY 'DELTANA' FASTENED TO FRAME AND LEAF WITH
 (4) #9 X 1" SCREWS

SOLID BRASS HINGES:

BY 'DELTANA' FASTENED TO FRAME AND LEAF WITH
 (4) #12 X 1-1/4" SCREWS

SEALANTS:

ALL JOINTS AND FRAME CONNECTIONS SEALED WITH
 WHITE/ALUMINUM COLORED SILICONE.

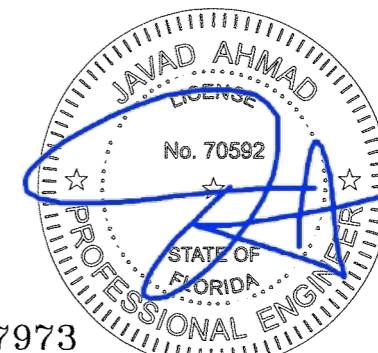

FL #27973

Sealed 8/24/2018

afc
AL-FAROOQ CORPORATION
 ENGINEERS & PRODUCT DEVELOPMENT
 9360 SUNSET DRIVE, SUITE 220 (C.A.N. 3538)
 MIAMI, FLORIDA 33173 FAX. (305) 262-6978
 TEL. (305) 264-8100 COMP-ANL \ 18-79F-EWD

INSWING WOOD ENTRANCE DOOR (N.I.)

Exclusive Wood Doors, Inc.
 2000 N.W. 95Th Ave.
 Doral, FL 33172
 Tel. (305) 477-2278 Fax. (305) 477-7140

revisions:	no	date	description

date: 08-13-18
 scale: 3/8" = 1"
 dr. by: TARIQ
 chk. by:

drawing no.
18-79F

sheet 6 of 10

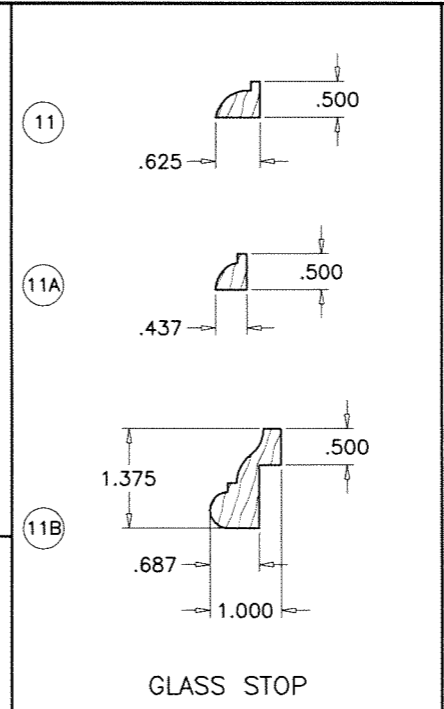
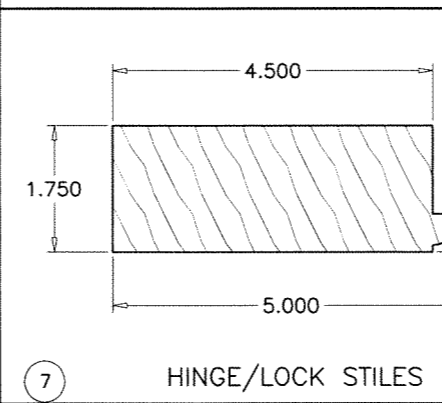
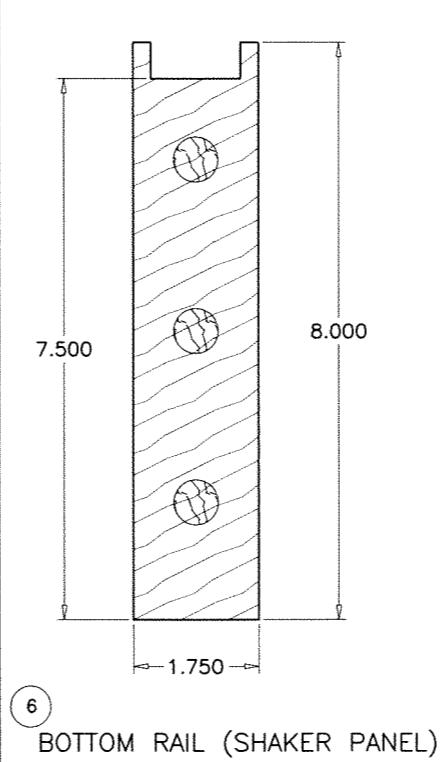
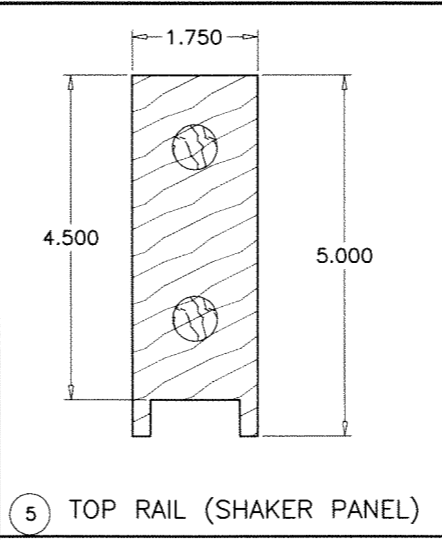
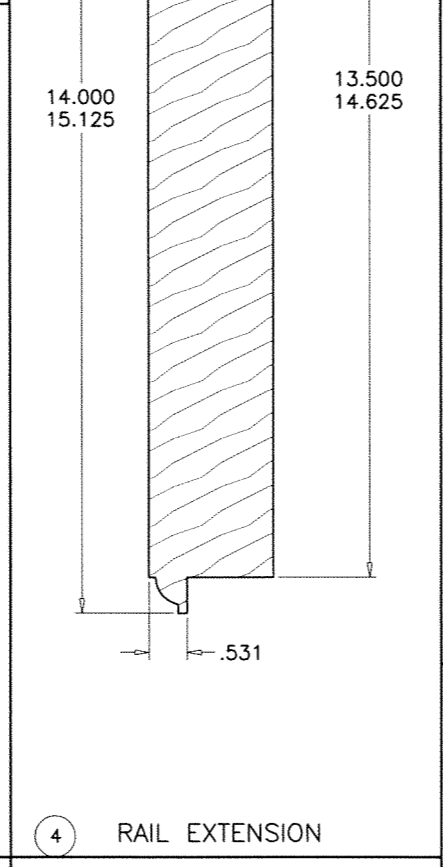
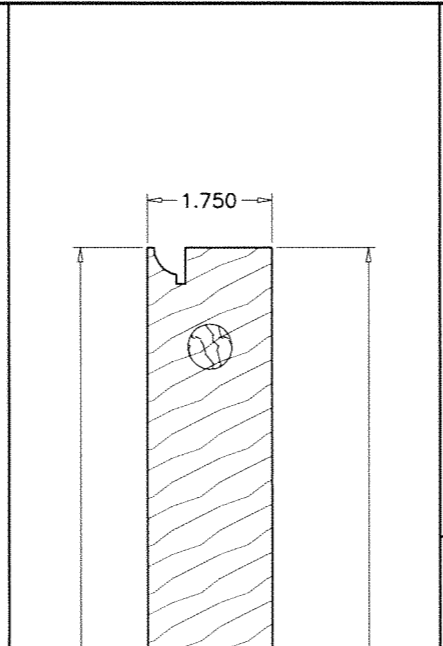
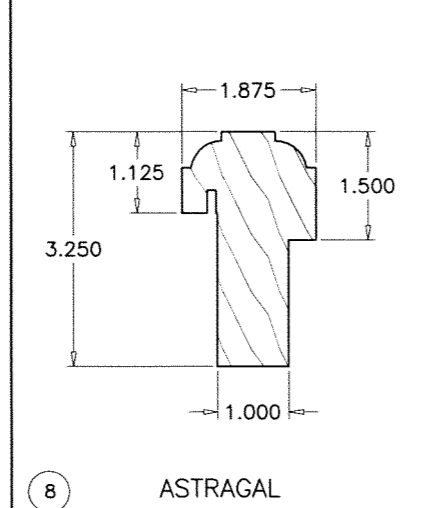
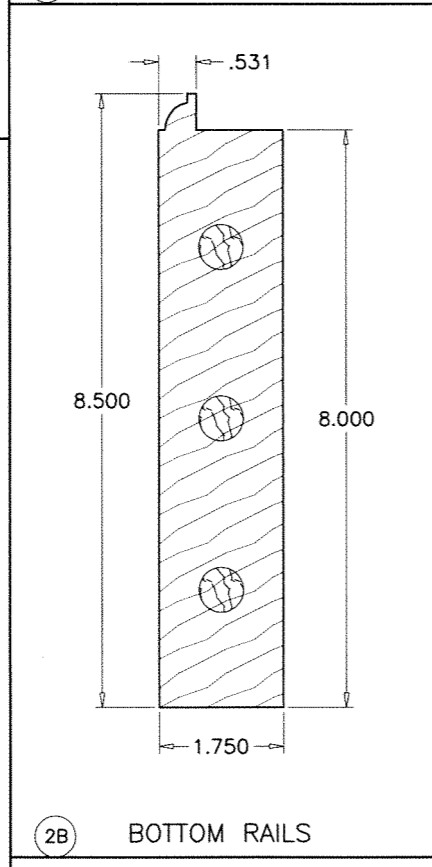
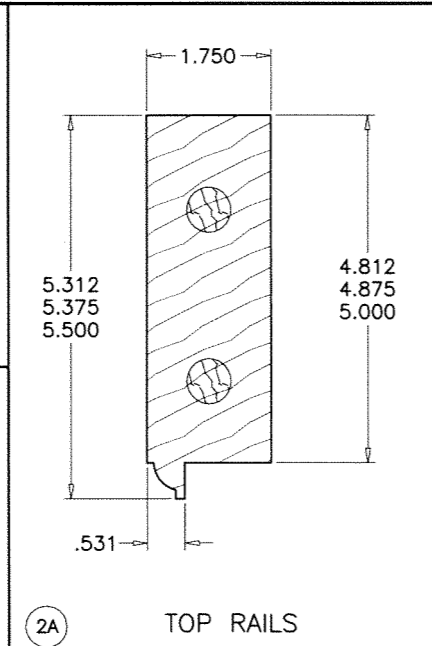
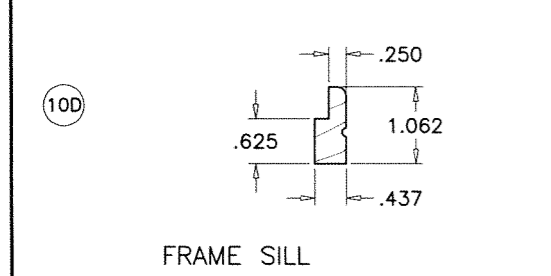
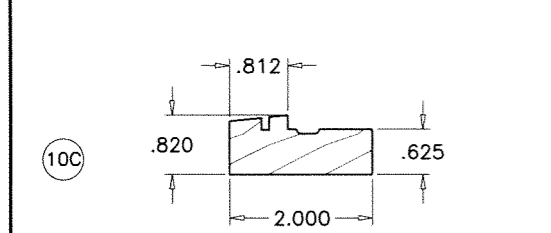
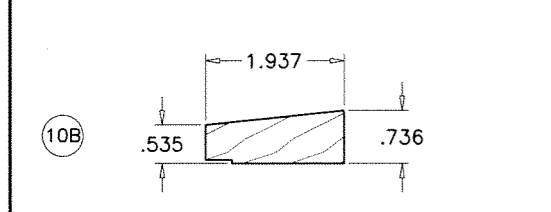
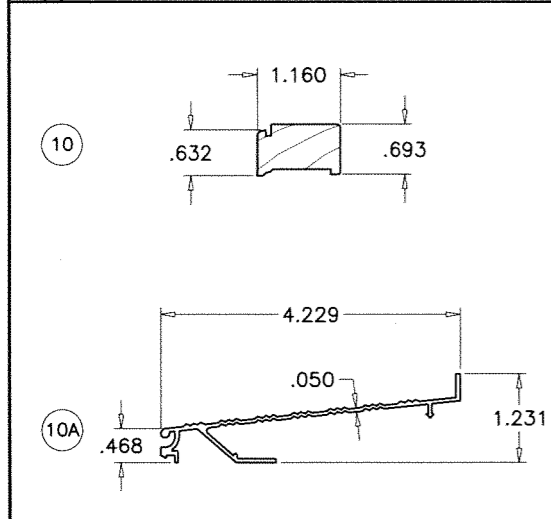
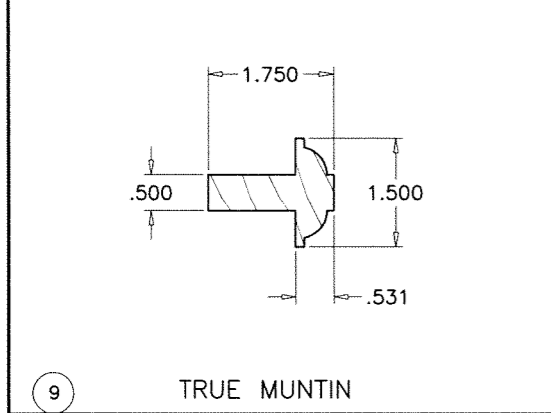
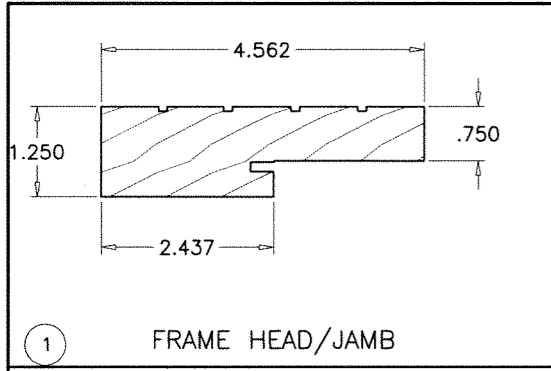

afc
AL-FAROOQ CORPORATION
 ENGINEERS & PRODUCT DEVELOPMENT
 9360 SUNSET DRIVE, SUITE 220 (C.A.N. 3538)
 MIAMI, FLORIDA 33173 FAX. (305) 262-6978
 TEL. (305) 264-8100 COMP-ANL \ 18-79F-EWD

INSWING WOOD ENTRANCE DOOR (N.I.)
Exclusive Wood Doors, Inc.
 2000 N.W. 95Th Ave.
 Doral, FL. 33172
 Tel. (305) 477-2278 Fax. (305) 477-7140

revisions:	no	date	by	description

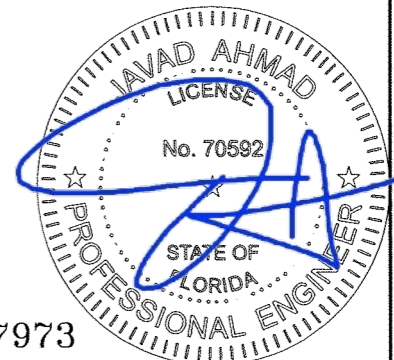

date: 08-13-18
 scale: 3/8" = 1"
 dr. by: TARIQ
 chk. by:
 drawing no.
18-79F
 sheet 7 of 10

FL #27973

Sealed 8/24/2018

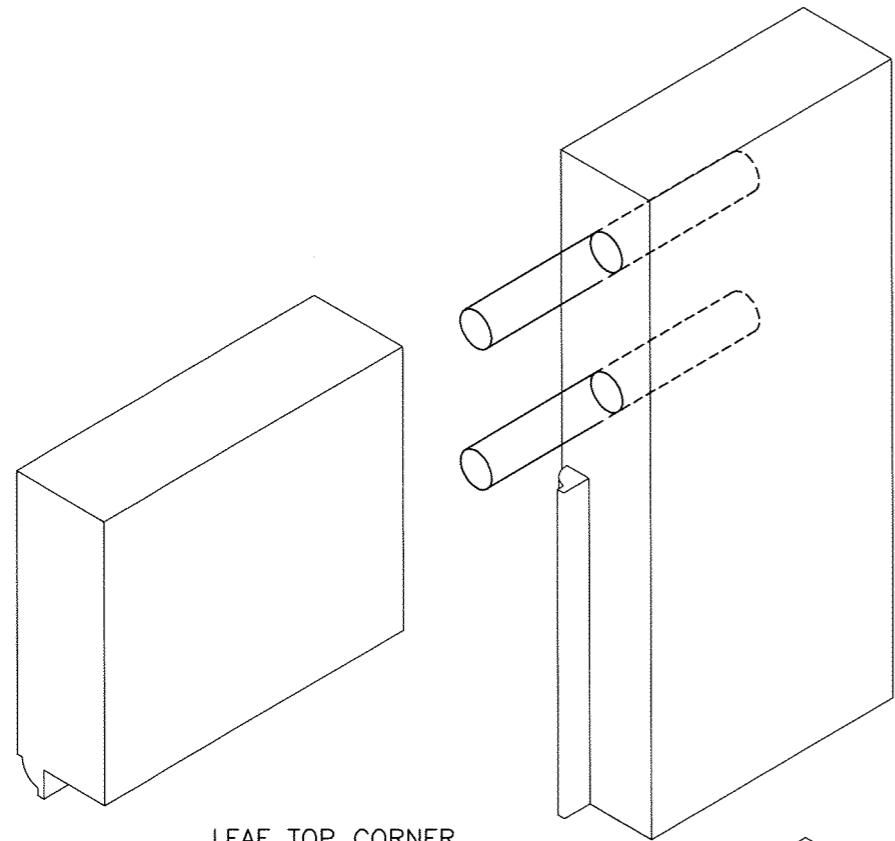

LEAF TOP CORNER

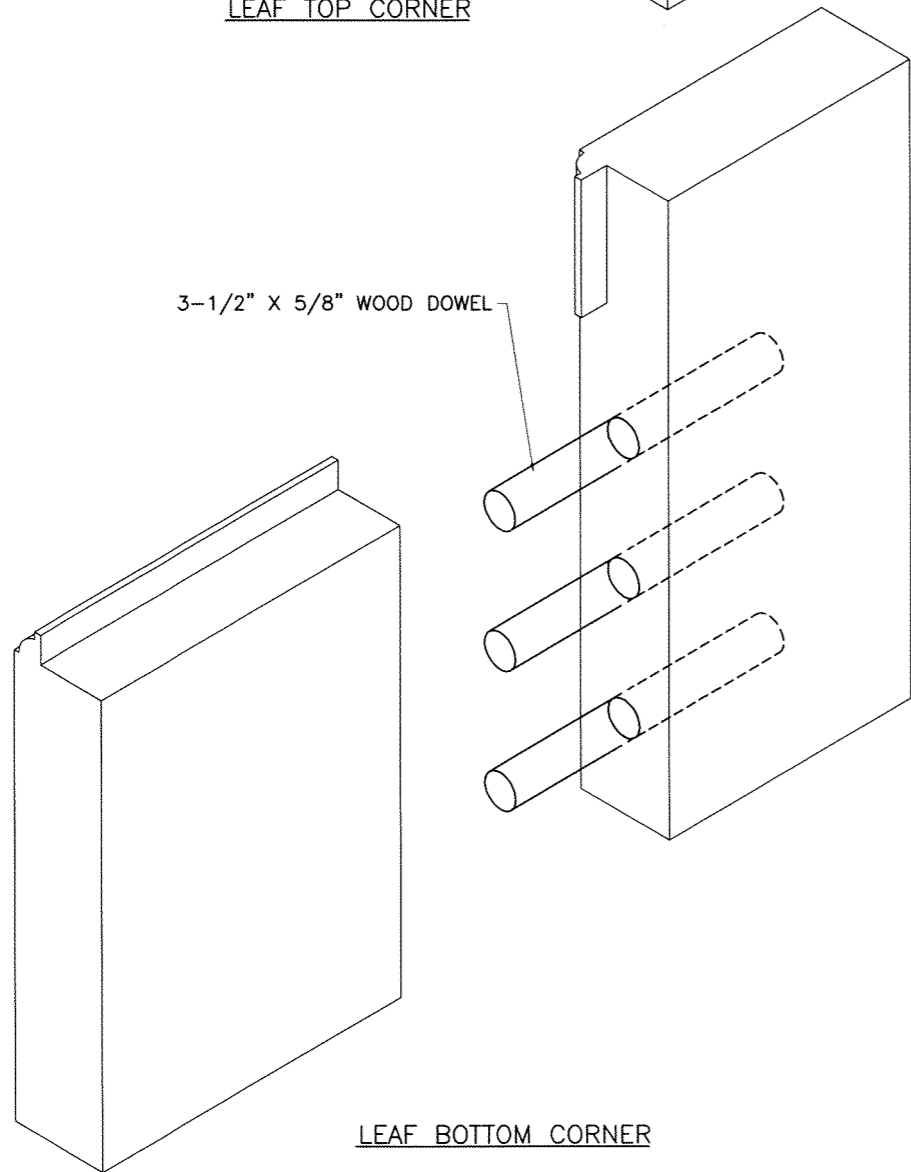

LEAF BOTTOM CORNER

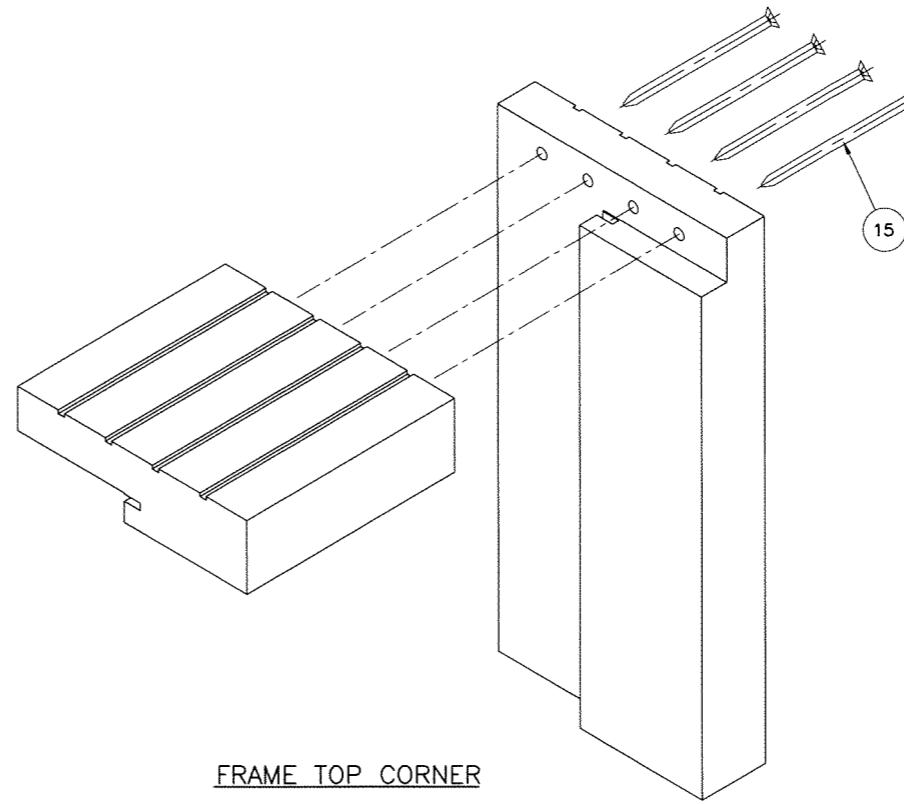

FRAME TOP CORNER

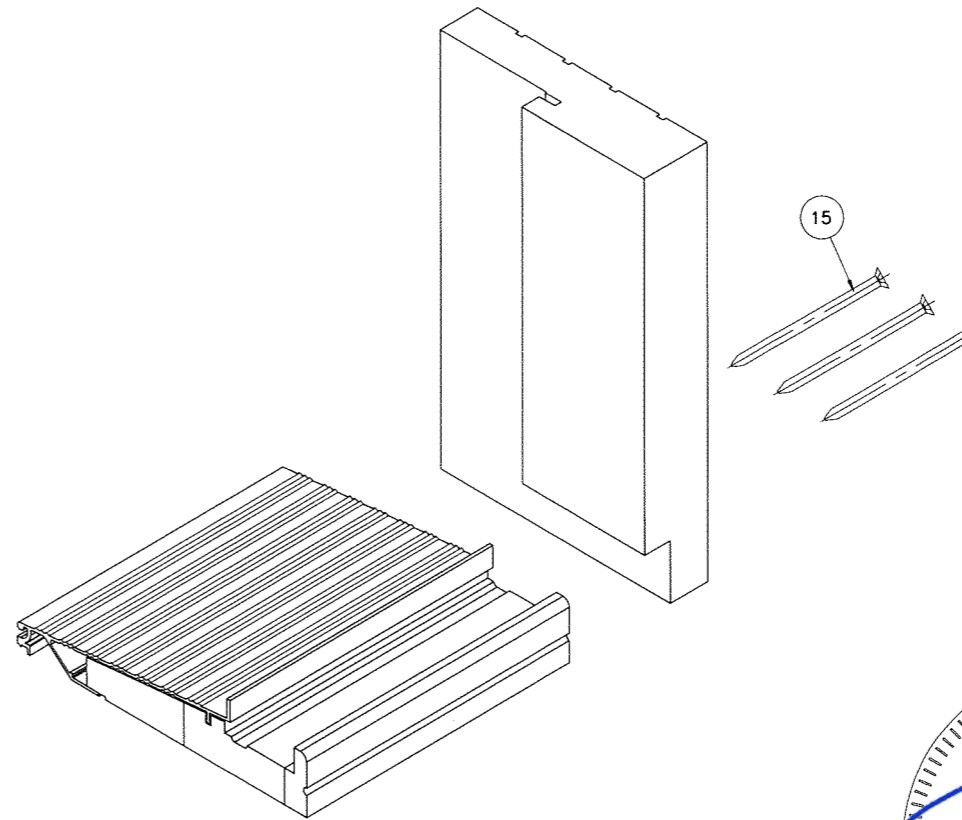

FRAME BOTTOM CORNER

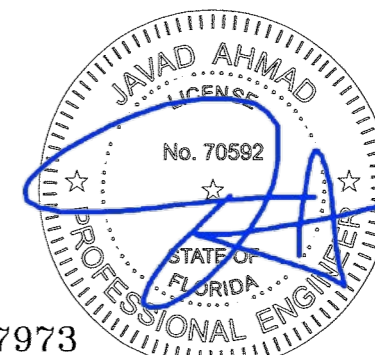

FL #27973

Sealed 8/24/2018

afc
AL-FAROOQ CORPORATION
 ENGINEERS & PRODUCT DEVELOPMENT
 9360 SUNSET DRIVE, SUITE 220 (C.A.N. 3538)
 MIAMI, FLORIDA 33173 TEL. (305) 262-6978
 TEL. (305) 264-8100 FAX. (305) 262-6978
 COMP-ANL\18-79F-EWD

INSWING WOOD ENTRANCE DOOR (N.I.)
Exclusive Wood Doors, Inc.
 2000 N.W. 95Th Ave.
 Doral, FL. 33172
 Tel. (305) 477-2278 Fax. (305) 477-7140

revisions:	no	date	by	description

date: 08-13-18
 scale: 3/8" = 1"
 dr. by: TARIQ
 chk. by:

drawing no.
18-79F

sheet 8 of 10

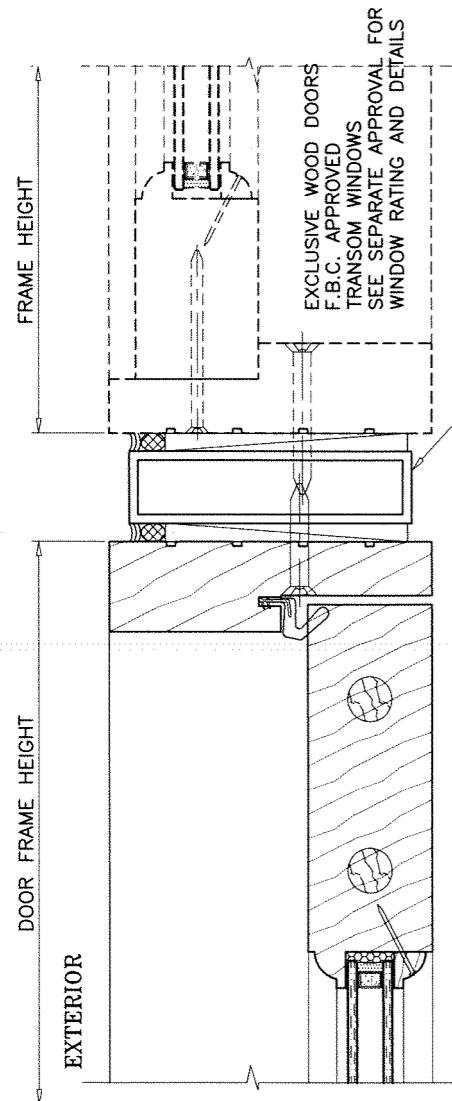

1 X 4 X 1/8"
ALUM TUBE
(6063-T5)

H

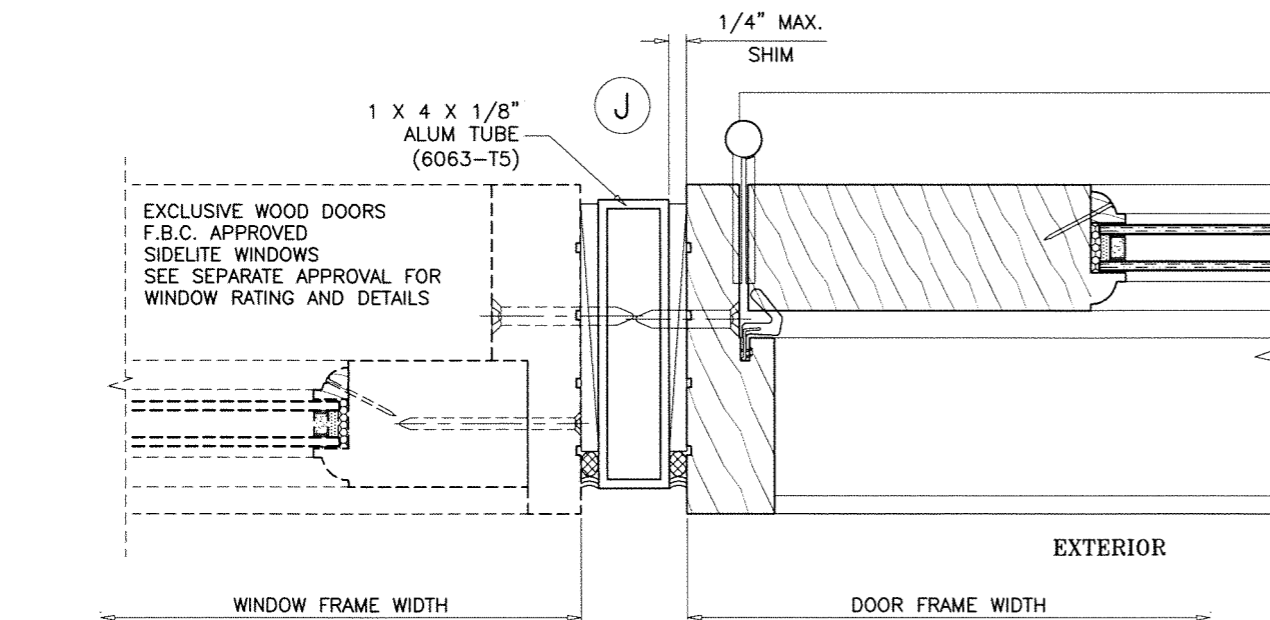
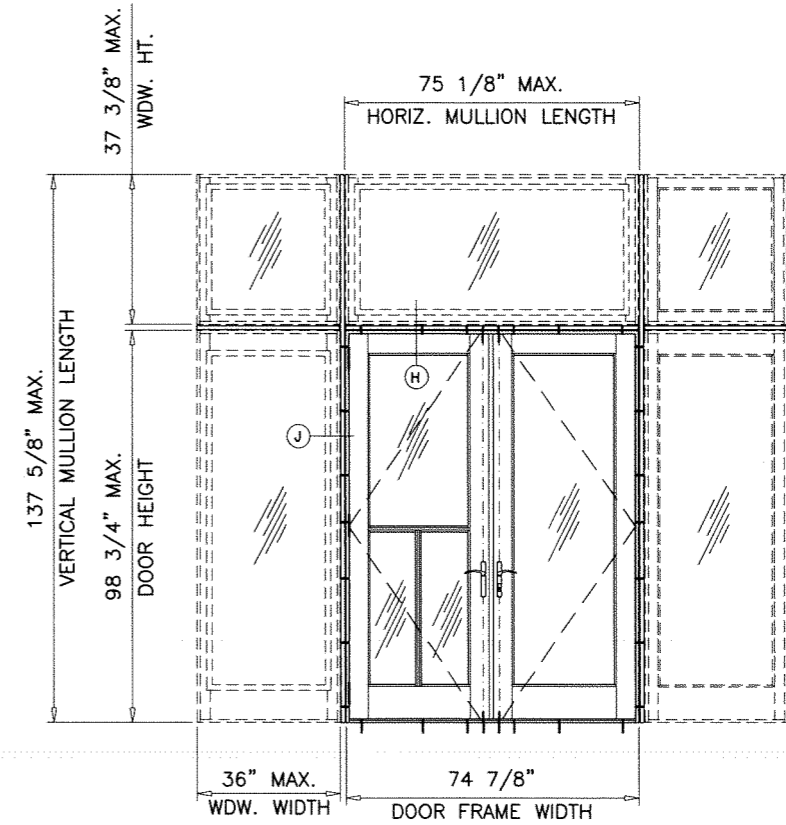
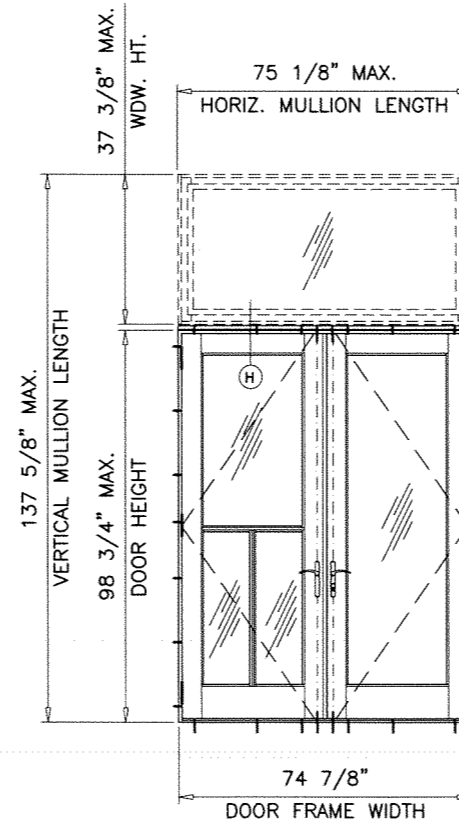
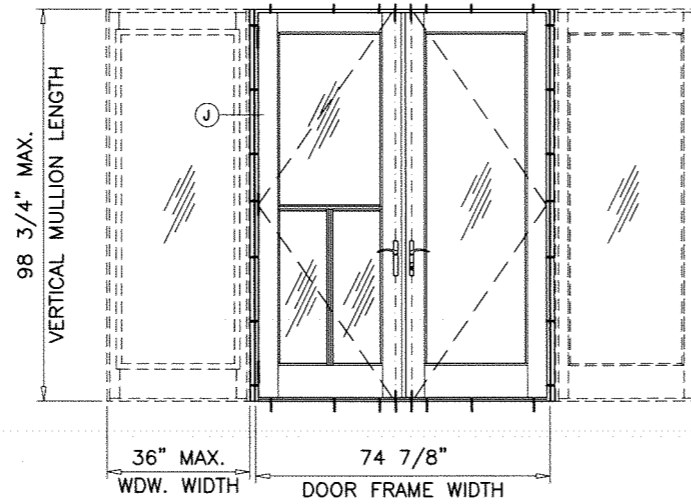

1 X 4 X 1/8"
ALUM TUBE
(6063-T5)

J

1/4" MAX.
SHIM

NOTES:

1. USE CHART ON SHEET 1 FOR DESIGN LOAD CAPACITY OF SINGLE AND DOUBLE DOORS.
 2. FOR EXCLUSIVE WOOD DOORS SIDELITE AND TRANSOM WINDOW CAPACITY SEE SEPARATE APPROVAL.
- LOWER VALUES FROM STEPS 1 OR 2 WILL APPLY TO ENTIRE SYSTEM.

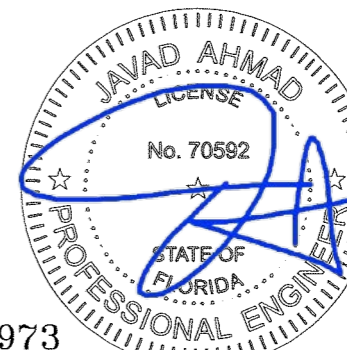

FL #27973

Sealed 8/24/2018

afc
AL-FAROOQ CORPORATION
ENGINEERS & PRODUCT DEVELOPMENT
9360 SUNSET DRIVE, SUITE 220 (C.A.N. 3538)
MIAMI, FLORIDA 33173
TEL. (305) 264-8100 FAX. (305) 262-6978
COMP-ANL \ 18-79F-EWD

INSWING WOOD ENTRANCE DOOR (N.I.)

Exclusive Wood Doors, Inc.
2000 N.W. 95Th Ave.
Doral, FL. 33172
Tel. (305) 477-2278 Fax. (305) 477-7140

revisions:	no.	date	description

date: 08-13-18
scale: 3/8" = 1"
dr. by: TARIQ
chk. by:
drawing no.
18-79F
sheet 9 of 10

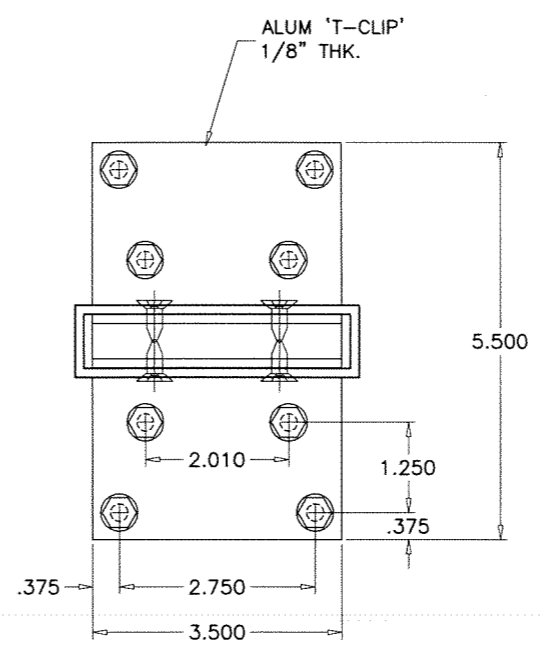
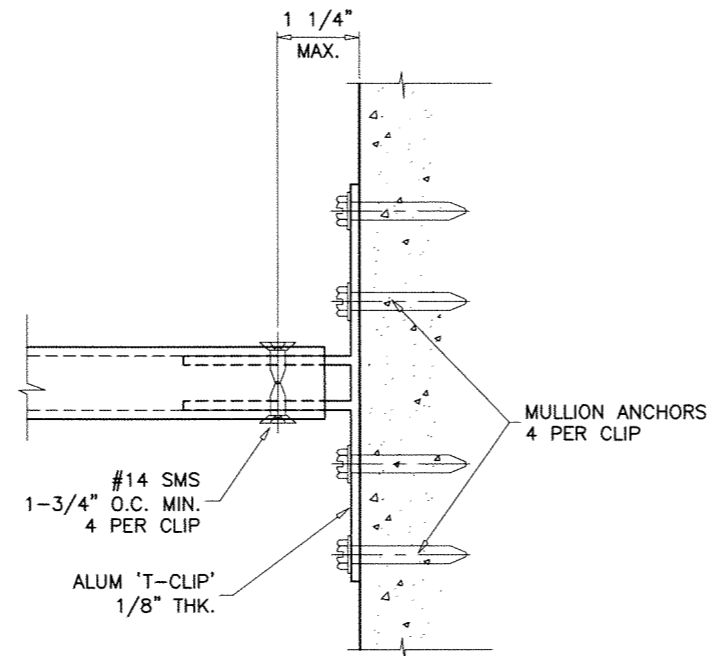
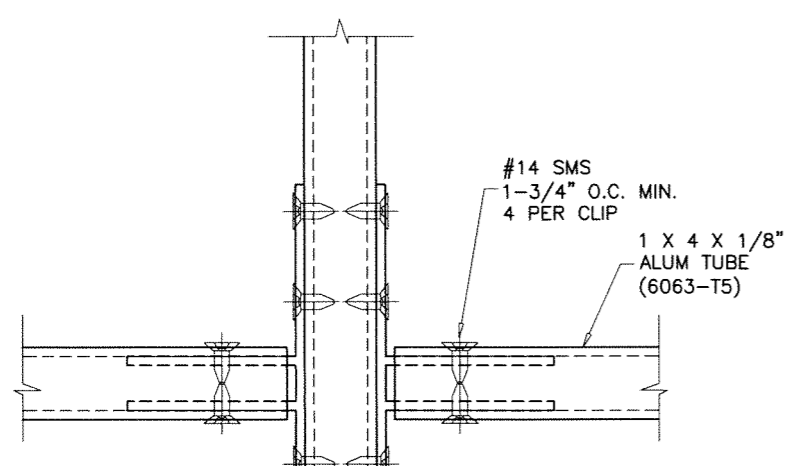

MULLION CONNECTION
 HORIZONTAL MULLION AT JAMBS

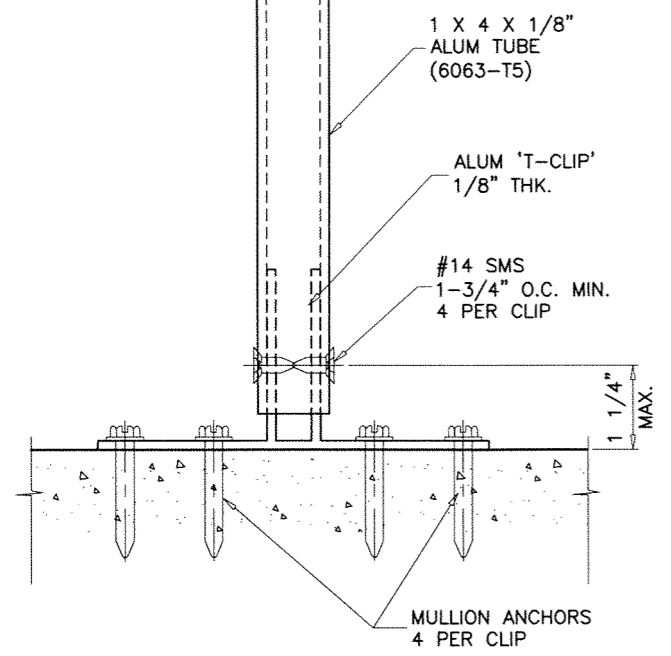

MULLION CONNECTION
 VERTICAL MULLION AT HEAD/SILL

MULLION ANCHORS: SEE ELEV. FOR SPACING
#14 WOOD SCREWS (GRADE 2 CRS)
 INTO 2BY WOOD BUCKS OR WOOD STRUCTURES
 1-1/2" MIN. PENETRATION INTO WOOD (HEAD/JAMBS)
1/4" DIA. TAPCON BY 'ITW' (Fu=125 KSI, Fy=100 KSI)
 THRU 1BY BUCKS INTO CONCRETE
 1-3/4" MIN. EMBED INTO CONCRETE (HEAD/JAMBS)
 DIRECTLY INTO CONCRETE
 1-3/4" MIN. EMBED INTO CONCRETE (HEAD/SILL/JAMBS)
1/4" DIA. ULTRACON BY 'ELCO' (Fu=177 KSI, Fy=155 KSI)
 THRU 1BY BUCKS INTO BLOCKS
 1-1/4" MIN. EMBED INTO BLOCKS (JAMBS)
 DIRECTLY INTO BLOCKS
 1-1/4" MIN. EMBED INTO BLOCKS (JAMBS)
1/4" DIA. TEKS OR SELF-DRILLING SCREWS (GRADE 5 CRS)
 INTO METAL STRUCTURES (HEAD/JAMBS)
 (3) THREADS MIN. TO EXTEND BEYOND METAL THICKNESS
 ALUMINUM: 1/8" THK. MIN. (6063-T5 MIN.)
 STEEL: 1/8" THK. MIN. (Fy = 36 KSI MIN.)
 (STEEL IN CONTACT WITH ALUMINUM TO BE PLATED OR PAINTED)

CRITICAL EDGE DISTANCE
 INTO CONCRETE AND BLOCKS = 2-1/2" MIN.
 INTO WOOD STRUCTURE = 1" MIN.
 INTO METAL STRUCTURE = 1/2" MIN.

WOOD AT HEAD OR JAMBS SG = 0.55 MIN.
 CONCRETE AT HEAD, SILL OR JAMBS f'c = 3000 PSI MIN.
 C-90 HOLLOW/FILLED BLOCK AT JAMBS f'm = 2000 PSI MIN.

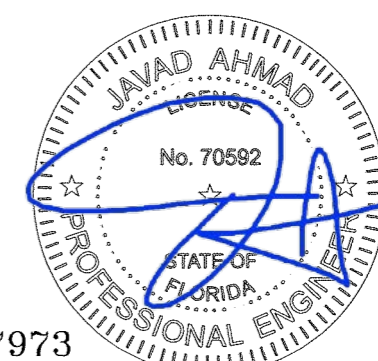

FL #27973

Sealed 8/24/2018

revisions:	no	date	description

date	08-13-18	scale	3/8" = 1"
dr. by:	TARIQ	chk. by:	
drawing no.	18-79F	sheet	10 of 10